



JOURNAL OF GAS TECHNOLOGY

Volume 6 / Issue 2 / Winter 2021 / Pages 45-52

Journal Homepage: <http://jgt.irangi.org>

Natural Gas Transmission in Dense Phase Mode

Mortaza Zivdar^{1*}, Moslem Abofarakh²

1. Professor, Chemical Engineering Department University of Sistan and Baluchestan, Zahedan, Iran

2. Msc. Student, Chemical Engineering Department University of Sistan and Baluchestan, Zahedan, Iran

ARTICLE INFO

ORIGINAL RESEARCH ARTICLE

Article History:

Received: 26 March 2021

Revised: 13 May 2021

Accepted: 29 June 2021

Keywords:

Dense Phase

Natural Gas Transmission

Pipelines

Simulation

ABSTRACT

Natural gas transmission processes in the pipeline encounter many problems, such as the high cost of purchasing and maintaining compressors in pressure boosting stations, the formation of gas hydrates, the formation of two-phase fluid, noise pollution, and service and maintenance costs of the pipeline. To solve these problems, natural gas transmission in the supercritical state (dense phase state) is recommended. Unfortunately, there is limited information on the transmission of natural gas in the dense phase. In this research, the natural gas transmission of Iran's fourth national pipeline in the supercritical state has been studied, and the results have been compared with the normal state. By performing this process in the dense phase mode, the number of pressure stations was reduced from 10 stations in the normal mode to 4 stations in the dense phase mode. The results of this study also showed that the pressure drop and energy of compressors in the dense phase state were reduced by 59% and 60%, respectively.

DOR: [20.1001.1.25885596.2021.7.2.4.6](https://doi.org/10.1001.1.25885596.2021.7.2.4.6)**How to cite this article**

M. Zivdar, M. Abofarakh. Natural Gas Transmission in Dense Phase Mode. Journal of Gas Technology. 2021; 6(2): 45 -52.
(http://jgt.irangi.org/article_251677.html)

* Corresponding author.

E-mail address: mzivdar@eng.usb.ac.ir (M. Zivdar)

Available online 26 December 2021

2666-5468/© 2021 The Authors. Published by Iranian Gas Institute.

This is an open access article under the CC BY license. (<https://creativecommons.org/licenses/by/4.0/>)

1. Introduction

Despite the advances in renewable energy, natural gas is still one of the primary needs for society and industry. The important issue, after dehydration and sweetening of natural gas, is the transmission of natural gas to industries, cities, and countries. There are methods such as pipeline, gas compression, conversion of natural gas to liquid, conversion of natural gas to valuable liquids, and etc.) Thomas, 2003(. The pipeline method is the most common method of transporting natural gas in most countries. However, the transmission of natural gas through the pipeline has problems such as the high cost of purchasing and maintaining compressors at pressure stations, the formation of gas hydrates, the presence of the two-phase fluid within the pipeline, noise pollution, and the cost of servicing and maintaining the pipeline (Dai et al, 2017; Wenyue, 2013; Wang and Xuan, 2013). Various works have been done to reduce the problems related to gas transmission in the pipeline. Shiekh (2013) examined the gas transmission process in the pipeline to minimize transmission costs. The results of this study showed that by optimizing design variables, such as diameter, the distances between the pressure stations, and condenser outlet pressure, the cost of gas transmission through the pipe reduced (Shiekh, 2013). Liu et al (2014) studied the gas transfer process to reduce energy consumption. The results of this study showed that by optimizing the pressure station and temperature parameters, energy consumption was reduced by 11 to 16% (Liu et al, 2014). Wu et al (2018) reviewed studies on pipeline optimization. Finally, they reported optimization algorithms that required less computation (Wu et al, 2018). According to the reviewed studies, all works were focused on optimizing design variables to reduce the problems and costs of the gas transmission pipelines. The results of these researches show that although using these methods was useful in reducing gas transmission problems in the pipeline, the use of new methods for further improvement of the

performance of gas transmission in pipelines is needed. Gas transmission in the pipeline in the dense phase mode is a suggestion to reduce the problems related to gas transmission in the normal state. In fact, in the dense phase state, the density of the fluid is similar to that of liquids, and its viscosity is similar to the gases. Due to the dual nature of the fluid, some problems created during the transfer of gas in the normal state are eliminated. To transfer natural gas to the dense phase state, the gas pressure should be higher than the maximum pressure in the phase diagram (Cricondenbar) and also the gas temperature should be higher than the critical temperature and lower than the maximum temperature in the two-phase region (Cricodentherm) (Moshfeghian, 2012; Zivdar and Abrofarakh, 2021). Despite the advantages of gas transmission in the dense phase state, there are not enough studies pertinent to gas transmission in the dense phase mode. This study considered the natural gas transmission of Iran's fourth pipeline in the dense phase state. The results of this case were compared with the results of gas transmission in normal conditions to show how dense phase has a better performance.

2. Mathematical

The one-dimensional equations of continuity, energy and momentum for the gas inside the pipeline are shown as follows, respectively (Helgaker and Ytrehus, 2012).

Continuity:

$$\frac{\partial \rho}{\partial t} + \frac{\partial(\rho u)}{\partial x} = 0 \quad (1)$$

Energy:

$$\rho C_v \left(\frac{\partial T}{\partial t} + u \frac{\partial T}{\partial x} \right) + T \left(\frac{\partial p}{\partial T} \right)_\rho \frac{\partial u}{\partial x} = \frac{f \rho u^3}{2D} - \frac{4U}{D} (T - T_a) \quad (2)$$

Momentum:

$$\frac{\partial(\rho u)}{\partial t} + \frac{\partial(\rho u^2 + p)}{\partial x} = - \frac{f \rho u |u|}{2D} - \rho g \sin \theta \quad (2)$$

In these equations ρ is density, u is velocity, C_v is Heat capacity at constant volume, T is temperature, p is pressure, f is the friction factor, and D is the diameter of the pipeline.

3. Case study

In this research, the aim is to transfer the natural gas of the fourth national pipeline to the dense phase state and compare it with the normal mode. Tables 1 and 2 show the natural gas components and the fourth national pipeline information, respectively.

Table 1. Gas components of the fourth national pipeline

Components	Percentage of molar fraction (%)
C ₁	90
C ₂	5
C ₃	0.6
NC ₄	0.1
NC ₅	0.06
C ₆	0.02
C ₇	0.02
N ₂	3.2
CO ₂	1

Table 2. Fourth pipeline information

Parameter	value
D (in)	56
Pin (Psia)	1250
Tin (°F)	120
L (km)	1140
n (lbmol/hr)	250000

Figure 1 shows the different areas of natural gas of the fourth national pipe line in the phase diagram

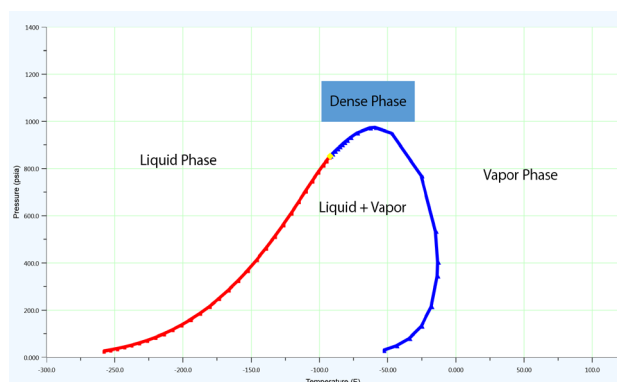

Figure 1. Different areas of natural gas of the fourth national pipeline in the phase diagram

According to Figure 1, to transfer the natural gas to the dense phase, the gas pressure and temperature along the entire length of the pipeline should be greater than 974 Pisa and -92 °F, respectively.

4. Simulation

In this section, pipeline simulations are performed in both normal and dense phase state with Aspen Plus software. One of the important parameters in the simulation is the selection of the appropriate thermodynamic package to calculate the physical and thermodynamic properties of the system. In this research, the Peng Robinson thermodynamic model is used (Kamal, 2002).

4.1. Simulation of the fourth pipeline in normal mode

The fluid enters the pipeline with the pressure of 1250 Pisa and enters the pressure station with a pressure of 1133 Pisa. Each pressure boosting station includes a compressor and a heat exchanger whose job is to bring the gas condition to the inlet state of the pipeline. In fact, Outlet gas from each section of the pipeline enters the pressure boosting station, and its pressure is increased. The temperature is also increased using a heat exchanger to reach the inlet temperature. There are 10 pressure boosting stations along the entire length of the pipeline, and each station is 114.5 km away from the next station. The simulation of the fourth pipeline with Aspen Plus software is shown in Figure 2.

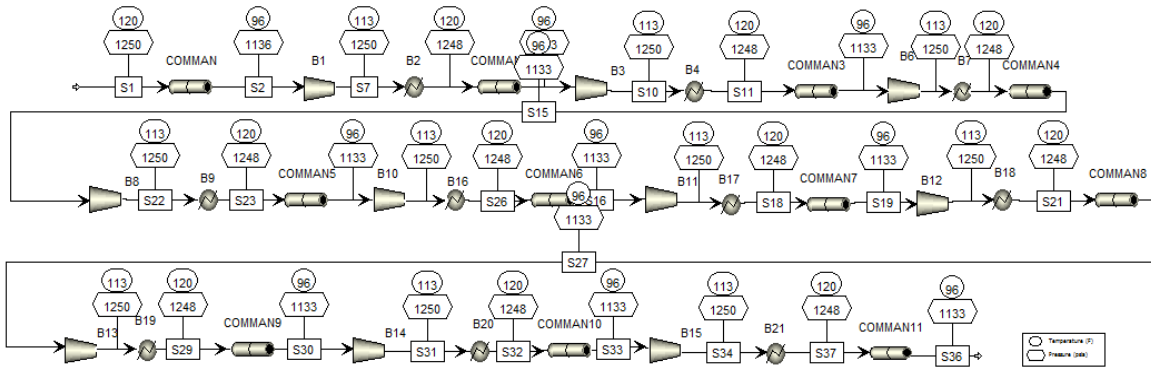

Figure 2. Fourth pipeline simulation in normal mode

4.1. Natural gas simulation of the fourth pipeline in dense phase mode

To transfer the gas to the dense phase area, it should be cooled from 120°F to -60°F at a constant pressure since the gas inlet pressure is more than 974 Pisa. Figure 3 shows the cooling of the inlet gas in a phase diagram.

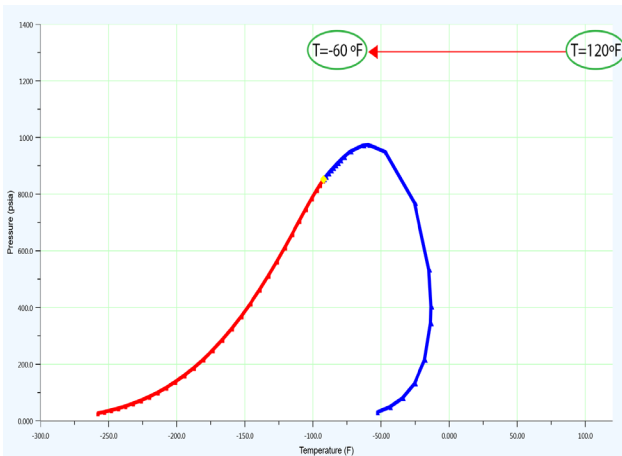

Figure 3. Cooling of natural gas at constant pressure

In the dense phase state, gas enters the pipeline with a temperature of -60°F and a pressure of 1250 Pisa. Since the pressure drop in the supercritical state is less than the normal state, less pressure boosting stations are needed in the supercritical state. The simulation of the fourth pipeline in supercritical mode with Aspen Plus software is shown in Figure 4. According to the less reduction of the pressure drop, it was found that the pressure boosting stations has been decreased from 10 to 4, while the distance between each pressure station and the next station is 228 km. The outlet pressure in each section before entering the pressure boosting station was equal to 1130 Pisa. In this case, 4 stations are responsible for bringing the gas to the temperature and natural gas pressure in the initial state. In fact, the outlet gas from each section of the pipeline enters the pressure boosting station, and its pressure increases to 1250 Pisa, then enters the heat exchanger to reach a temperature of -60°F.

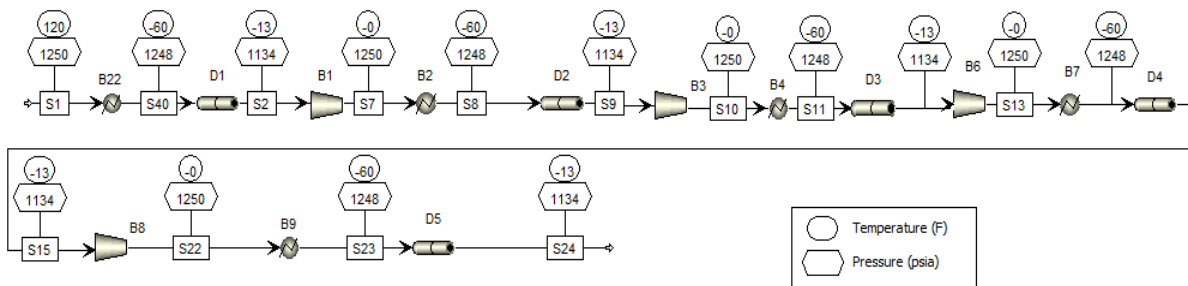

Figure 4. Fourth national pipeline simulation in dense phase mode

5. Results and discussion

In this research, the fourth pipeline is simulated in both normal and supercritical conditions. The results obtained from these two cases are compared as:

5.1. Temperature and pressure changes in supercritical state

Figure 5 shows the phase diagram of temperature and pressure changes in the supercritical state along 228 km of the pipeline. In this figure, state 1 shows the temperature and pressure conditions of the inlet, and state 2 shows the outlet conditions.

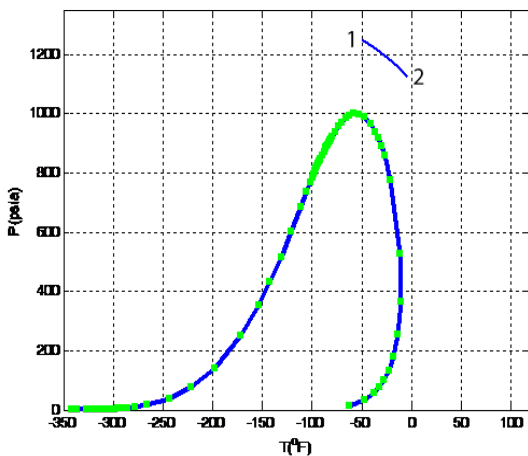

Figure 5. Temperature and pressure changes in the pipeline in supercritical state: 1: Input conditions 2: outlet conditions from the pipeline

5.2. Checking of hydrate formation in the supercritical state

Figure 6 is considered to check the formation of gas hydrate, which is one of the problems related to the normal transfer of gas through the pipeline. According to Figure 6, it is clear that in the entire length of the pipeline in the dense phase state, the fluid conditions are far from the hydrate formation condition as well as the two-phase fluid formation. Due to the absence of gas hydrates and also the absence of two-phase fluid inside the pipeline, the cost of

service and maintenance of the pipeline in the supercritical condition was reduced.

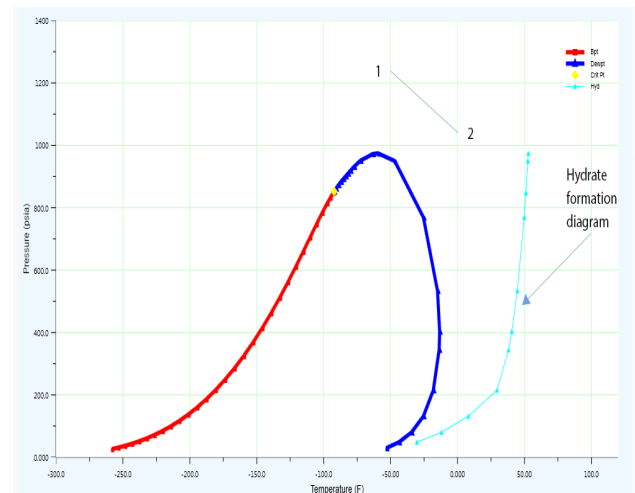

Figure 6. Gas hydrate diagram: 1: Input conditions 2: Output conditions from the pipeline

5.3. Comparison of the outlet pressure in both normal and dense phase modes

Figure 7 shows the comparison between the outlet pressure in both cases of the normal and dense gas transmission. According to Figure 7, the output pressure in the dense phase state is 53% lower than in the normal state. The reason for the lower output pressure in the supercritical state is the lower viscosity of the gas in the supercritical state compared to the normal state.

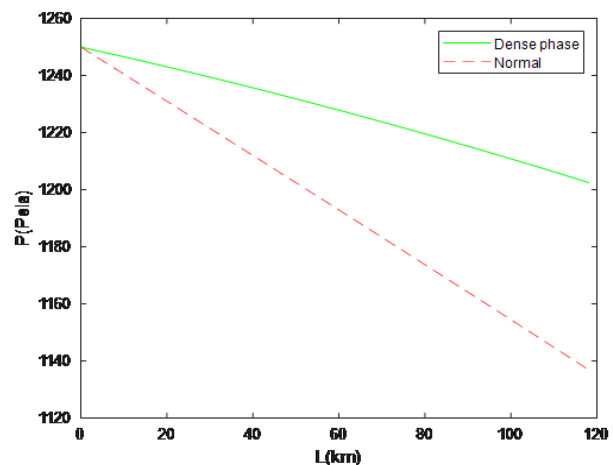

Figure 7. Outlet pressure changes in both dense phase and normal cases.

5.4. Checking the pressure drop in both normal and dense phase mode

In order to show the difference between the pressure drops in the pipeline, the amount of pressure drop at a certain distance in the pipeline is compared in both cases. Figure 8 shows the result of this comparison. According to Figure 8, the pressure drop in the supercritical mode is 59% less than the normal mode. Therefore, the number of pressure stations in the supercritical state is reduced compared to the normal state. So, the need to purchase a large number of compressors and the cost of installation and maintenance in the gas transmission path is significantly reduced. Also, due to the high noise created in pressure boosting stations, with the reduction of stations, the amount of noise pollution in the areas will decrease.

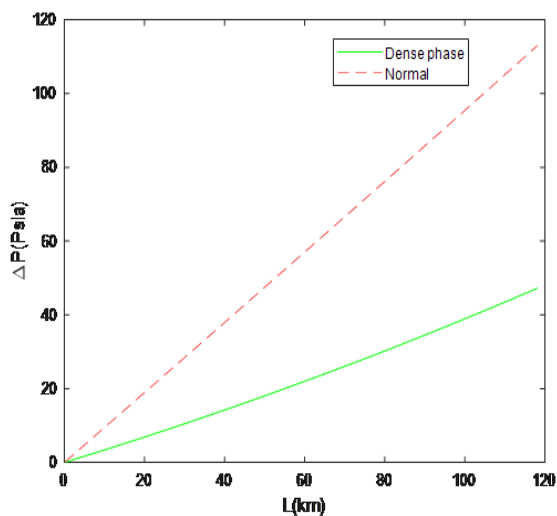

Figure 8. Pressure drop changes in the both dense and normal cases

5.5. Temperature changes in both normal and dense phase states

Figure 9 shows the temperature changes along the pipeline for both normal and dense phase modes. According to the figure, in both cases, the temperature changes were almost the same.

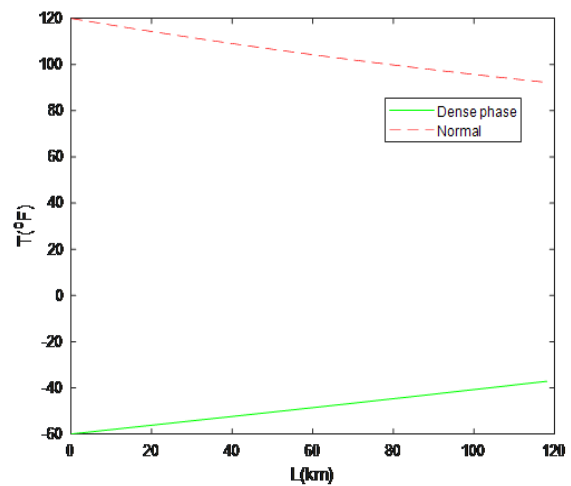

Figure 9. Temperature changes for the two cases

5.6. Comparison of compressor power and heat exchanger energy values in both normal and supercritical modes

Tables 3 and 4 show the power values of compressors and heat exchangers in two modes.

Table 3. Compressor power consumption for the two cases

Compressor power in dense phase mode (hp)	Compressor power in normal mode (hp)
56424	141060

According to Table 3, the power values of the compressors in the supercritical mode is 60% less than the normal mode, which indicates the reduction of the problem related to the high power required for the compressors in the normal gas transfer process.

Table 4. Energy required in the heat exchangers

Energy of heat exchangers in supercritical mode (MW)	Energy of heat exchangers in normal mode (MW)
563	58.7

According to the results of Table 4, it is clear that the amount of energy required for the heat exchanger in the dense phase mode is more than the normal mode, which is due to the cooling of the gas in the supercritical process.

6. Conclusion

In this research, gas transmission simulations in the pipeline in normal and dense phase conditions have been performed, and the performance of these two cases have been compared. The results of this study showed that by using the fluid in the dense phase mode, the gas transmission performance in the pipeline had been greatly improved so that:

- The outlet pressure in the supercritical mode was 53% less than the normal mode. Also, the pressure drop in the supercritical state was 59% less than usual. Therefore, the number of pressures boosting stations in the supercritical mode has been decreased from 10 stations to 4 stations.
- The cost of installation and maintenance of compressors was reduced due to a significant reduction of the pressure boosting stations. Also, due to the high noise of the station, with the decrease in the station numbers, noise pollution in the areas was reduced.
- The energy requirement of the compressors in the supercritical state was 60% less than the normal state, which shows a solution for the problem related to the high power required for the compressors in the normal gas transfer process.
- No hydrates and two-phase fluid were formed along the pipeline in the supercritical state. So, the cost of servicing and maintaining the pipeline in the supercritical state has been reduced.

Nomenclature

C_v	Heat capacity at constant volume (J/(kg.K))
D	Diameter (m)
F	Friction factor
L	Length (km)
P	Pressure (Pa)
T	Temperature (°C)
U	Heat transfer coefficient (W/ (m ² .K))
u	Velocity (m/s)
T	Temperature (°C)
T_a	Ambient temperature (°C)
<i>Greek letters</i>	
ρ	Density (kg/m ³)

References

- Dai, L., Wang, D., Wang, T., Feng, Q., Yang, X., 2017. Analysis and Comparison of Long-Distance Pipeline Failures. *Petroleum Engineering*, 2017, Article ID 3174636. <https://doi.org/10.1155/2017/3174636>.
- Helgaker, H., Ytrehus, T., 2012. Coupling between Continuity/Momentum and Energy Equation in 1D Gas Flow. *Energy Procedia*. 26, 82-89. <https://doi.org/10.1016/j.egypro.2012.06.013>.
- Kamal, K.B., 2002. Performance of five equations of state for the prediction of VLE and densities of natural gas mixtures in the dense phase region. *Chem. Eng. Comm.*, 189, 151-172. <https://doi.org/10.1080/00986440211837>.
- Liu, E., Li, CH., Yang, Y., 2014. Optimal Energy Consumption Analysis of Natural Gas Pipeline. *The Scientific World Journal*. 2014, PMC4053082. <https://doi.org/10.1155/2014/506138>.
- Moshfeghian, M., 2012., *Gas Processing, Process Facilities*, <http://www.jmcampbell.com/tip-of-the-month/2012/08/transportation-of-natural-gas-in-dense-phase/>.

- Shiekh, T.M., 2013. The Optimal Design of Natural Gas Transmission Pipelines. *Energy Sources, Part B: Economics Planning and Policy*. 8, 7-13. <https://doi.org/10.1080/15567240802534193>.
- Thomas, S., Dawe, R., 2003. Review of Ways to Transport Natural Gas Energy from Countries Which Do Not Need the Gas for Domestic Use. *Energy*. 28, 1461-1477. [https://doi.org/10.1016/S0360-5442\(03\)00124-5](https://doi.org/10.1016/S0360-5442(03)00124-5).
- Wang, T., Xuan, W., Wang, X., Ren, K., 2013. Overview of oil and gas pipeline failure database. *International Conference on Pipelines and Trenchless Technology. ICPTT, 2013*, 1161-1167. <https://doi.org/10.1061/9780784413142.121>.
- Wenyue, Z., 2013. corrosion cracking of oil and gas pipelines in near neutral pH environment: Review of recent research. *Energy Materials: Materials Science and Engineering for Energy Systems*. 3, 220-226. <https://doi.org/10.1179/174892309X12555944292234>.
- Wu, X., Li, Y., He, Y., Jia, W., 2018. Operation Optimization of Natural Gas Transmission Pipelines Based on Stochastic Optimization Algorithms: A Review. *Mathematical Problems in Engineering*, 2018, Article ID 1267045. <https://doi.org/10.1155/2018/1267045>.
- Zivdar, M., Abrofarakh, M., Investigating the Natural Gas Transmission in Supercritical Condition. *Iranian Chemical Engineering Journal*. 20 (16), 50-63. Doi: 10.22034/ijche.2021.257914.1070.

انتقال گاز طبیعی در حالت فوق بحرانی

• مرتضی زیودار^{۱*}، مسلم ابروفراخ^۲

۱. استاد مهندسی شیمی، دانشکده مهندسی شیمی، دانشگاه سیستان و بلوچستان، زاهدان، ایران

۲. دانشجوی کارشناسی ارشد مهندسی شیمی، دانشگاه سیستان و بلوچستان، زاهدان، ایران

(ایمیل نویسنده مسئول: mzivdar@eng.usb.ac.ir)

چکیده

در فرایند انتقال گاز طبیعی در خط لوله مشکلاتی نظیر هزینه‌ی بالای خرید و نگهداری کمپرسورها در ایستگاه‌های تقویت فشار، تشکیل هیدرات‌گازی، تشکیل جریان دوفازی، آلودگی صوتی و هزینه بر بودن سرویس و نگه‌داری خطوط لوله وجود دارد. برای کاهش این مشکلات انتقال گاز طبیعی در حالت فوق بحرانی پیشنهاد می‌شود. متأسفانه اطلاعات بسیار محدودی در زمینه انتقال گاز طبیعی در حالت فوق بحرانی وجود دارد. در این تحقیق انتقال گاز طبیعی خط لوله سراسری چهارم ایران در حالت فوق بحرانی بررسی شده و نتایج آن با انتقال گاز در حالت معمولی مقایسه شده است. با انجام فرایند در حالت فوق بحرانی، تعداد ایستگاه‌های تقویت فشار از ۱۰ ایستگاه در حالت معمولی به ۴ ایستگاه کاهش یافت. همچنین نتایج این تحقیق نشان داد که افت فشار و انرژی کمپرسورها در حالت فوق بحرانی به ترتیب به اندازه ۵۹٪ و ۶۰٪ نسبت به حالت معمولی کاهش یافته است.

واژگان کلیدی: حالت فوق بحرانی، انتقال گاز طبیعی، خطوط لوله، شبیه‌سازی